

SERVICE LIFTS



Move items

from floor to floor at the touch of a button



designed to impress[®]



easy living[®]
home elevators

SERVICELIFT RANGE

ISO A SERVICE LIFT

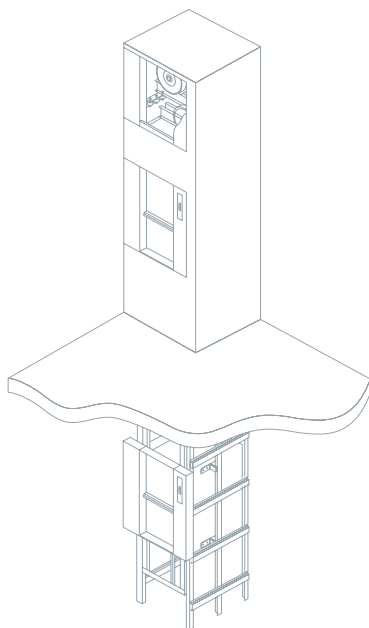

- Bi-parting doors at serving height
- No pit requirements
- Stainless or galvanised finishes
- Machine room location above, to the side or at the rear
- 240 or 415 volt supply
- 50-300kg capacity

ISO C SERVICE LIFT

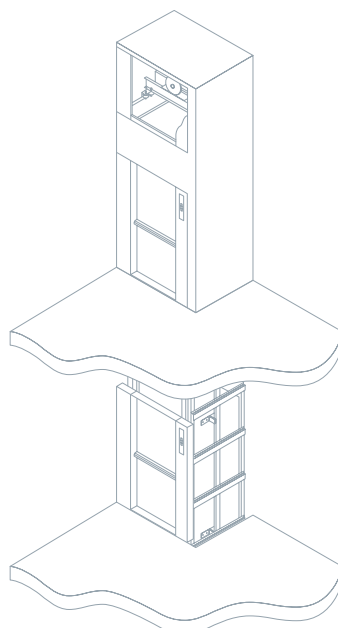

- Bi-parting doors serving at floor level
- Minimum pit requirements
- Stainless, galvanised or baked enamel finishes
- Machine room location above, to the side or at the rear
- 415 volt supply
- 50-300kg capacity

ISO D SERVICE LIFT

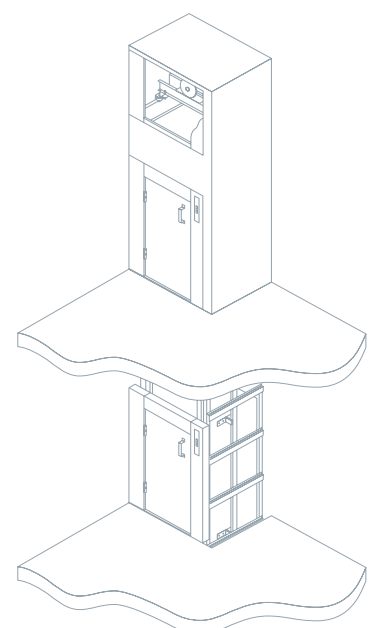

- Swing open doors serving at floor level
- Minimum pit requirements
- Stainless, galvanised or baked enamel finishes
- Machine room location above, to the side or at the rear
- 415 volt supply
- 50-300kg capacity

Capacity Kgs	Speed m/sec	Car size increases by 50 mm	Shaft dims mm	Headroom mm	Serv. height mm
50 - 100	0,4	Width 400 - 1000	+ 300	Serv. height	min. 700
		Depth 500 - 1000	+ 150	+ door height	lowest floor
		Height 600 - 1200		+ 1260	1/2 door height + 50
150 - 300	0,25	Width 500 - 1000	+ 300	Serv. height	min. 700
		Depth 600 - 1000	+ 150	+ door height	lowest floor
		Height 600 - 1200		+ 1360	1/2 door height + 50

NOTE:
On cabin protection clear entrance dimensions resp. shaft dimensions will change.
Minimum floor to floor height on doors in line = 2 x door height + 290 mm

Capacity Kgs	Speed m/sec	Car size increases by 50 mm	Shaft dims mm	Headroom mm	Serv. height mm
50 - 100	0,27	Width 400 - 1000	+ 350	Door height	min. 1/2 DH + 50
		Depth 600 - 1000	+ 150	+ 1260 mm	
		Height 800 - 1200			
150 - 300	0,25	Width 500 - 1000	+ 350	Door height	min. 1/2 DH + 50
		Depth 600 - 1000	+ 150	+ 1360 mm	
		Height 800 - 1200			

NOTE:
On cabin protection clear entrance dimensions resp. shaft dims will change.
Minimum floor to floor height on doors in line = 2 x door height + 290 mm

Capacity Kgs	Speed m/sec	Car size increases by 50 mm	Shaft dims mm	Headroom mm	Pit mm
50 - 100	0,27	Width 400 - 1000	+ 350	Door height	min. 350
		Depth 600 - 1000	+ 150	+ 1260 mm	
		Height 800 - 1200			
150 - 300	0,25	Width 500 - 1000	+ 350	Door height	min. 350
		Depth 600 - 1000	+ 150	+ 1360 mm	
		Height 800 - 1200			

NOTE:
On cabin protection clear entrance dimensions resp. shaft dims will change.

“Add value and safety to your home”

designed to impress®

ISO MAX 500/750/1000 Hoist



ISO D lifts - in clinics and hospitals

“Customised to suit your needs”

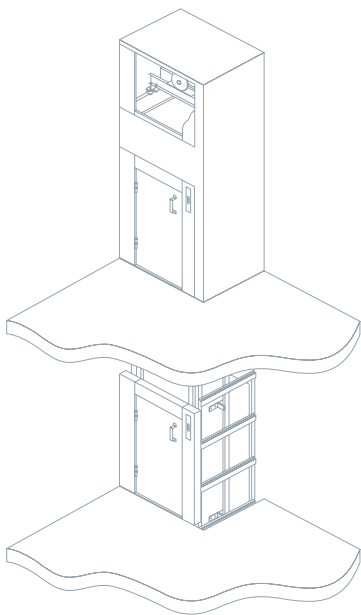

- Swing or double swing doors on open landing
- 270mm pit required
- Accepts standard pallets
- Galvanised finishes
- Completely free standing
- 415 volt supply
- 500-1000kg capacity

Many options are available in the ISO-MAX 500/750/1000kg range. Please contact Easy Living Home Elevators for more information.

STRENGTHS

- Manufactured to Australian Standards AS1735.4
- Low cost
- Custom designed to suit your application
- Stainless steel cars and doors
- Optional self supporting tower.
- Minimal pit requirement
- Space saving
- Various machine cabinet locations
- Power operated
- Various opening configurations
- Short delivery and installation times

“Our ServiceLifts can be used for almost any purpose and can be custom made according to your specification.”

Easy Living Home Elevators specialise in ServiceLifts and goods lifts for vertical transportation in restaurants, hotels hospitals and private homes. German quality ensures our guarantee of reliability and safety with an emphasis placed on high quality materials and lift design to meet your every need and function.

Easy Living Home Elevators understands each product is quite unique, you are not stuck with “standard” sizes, every ServiceLift is custom designed to suit your application. With variations in weight carrying capacities, travel distances, door openings and the type of doors required.

Each ServiceLift is designed with space saving features including minimal pit requirements and various machine cabinet locations – above, to the side or the rear of the ServiceLift. Ensuring your building space is optimised making the Easy Living ServiceLift very easy to accommodate into your new or existing project. Builders work requirement is also at a minimum, leading to a very fast and easy installation.

Every ServiceLift is designed, developed and manufactured to the highest Australian quality and safety standards for peace of mind.



easy living[®]
home elevators
designed to impress[®]

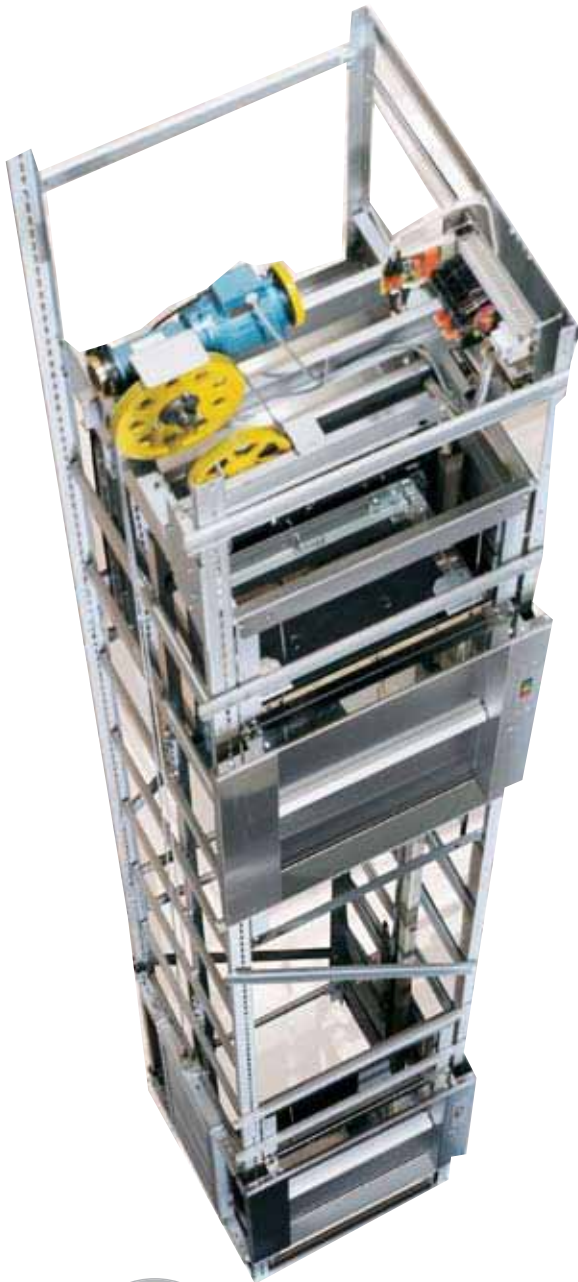

SERVICELIFT SPECIFICATIONS

Steel Structure

Self supporting steel structure, made of cold rolled special profiles, fully galvanised, pre-assembled in 2m sections including trunking.

Car

Made of folded stainless steel or galvanized steel sheets, centered suspension, guided on both sides with adjustable guide shoes. All units at serving height are supplied with a removable shelf. Car dimensions are available in increments of 25mm.

Landing Doors

Depending on the type of lift, bi-parting, single or double hinged doors in accordance with Australian Standards are provided, with a stainless steel or galvanised finish and specially tested door locks. Bi-parting doors suspended with 2 high flexible steel ropes, guided with aluminium sheaves in cage. All doors are provided with door frame surrounds for easy installation. Fire rated landing doors are available upon request.

Counterweight

Incorporates a steel frame with 50 x 50mm steel inserts. Four adjustable guide shoes with polyamid inserts.

Machine Room Door

Single hinged door, or double hinged for widths over 800mm. Stainless steel or galvanised finished door incorporating a lock and frame surrounds.

Drive Unit

Up to 100 kg capacity with sheave drive for 2 or 3 ropes. Units with 200 and 300kg capacity with chain drive for 2 chains. High quality reduction gear with motor, magnetic disc brake and handwheel. Easy Living Home Elevators also have other drives available e.g. drum, sheave, traction with the motors available on the side, rear, top and bottom.

Control

- Micro-processor controller
- safety High standard using a 24 Volt system on all push button units.
- Prewired and plug-in-system
- Call and send on each landing station
- Despatching delay device (of up to 5 seconds delay)
- Arrival buzzer and call signal
- Position indicator on each landing station
- Overload protection installed on control panel
- Machine room light with switch and socket.

DISCLAIMER:

All illustrations, photography and specifications contained in this brochure are based on the latest product information available at the time of publication. Easy Living Home Elevators Pty Limited reserves the right to make changes at any time, without notice in colours, materials, equipment, specifications, models and warranty. Any variations in colours shown are due to reproduction variations of the printing process.

Trademarks include: "designed to impress", "Easy Living Home Elevators".



Quality
Endorsed
Company
ISO 9001 Lic. QEC 20037
SAI Global

Contact Your Nearest Easy Living Home Elevators Showroom
sales@easy-living.com.au

NSW

64 Penshurst St
Willoughby NSW 2068
T. 02. 8116 1500
F. 02. 8116 1511

VIC - SA - TAS

7 Hoddle St
Collingwood VIC 3066
T. 03. 9094 8600
F. 03. 9094 8611

QLD

17 Campbell St
Bowen Hills QLD 4006
T. 07. 3851 7500
F. 07. 3851 7511

WA

23 Plaistowe Mews
West Perth WA 6005
T. 08. 9322 4688
F. 08. 9322 4655

www.easy-living.com.au