

SHAFT AND CAR PLAN  
 - DOORS HINGED ON RAIL SIDE  
 - TOWER STRUCTURE.

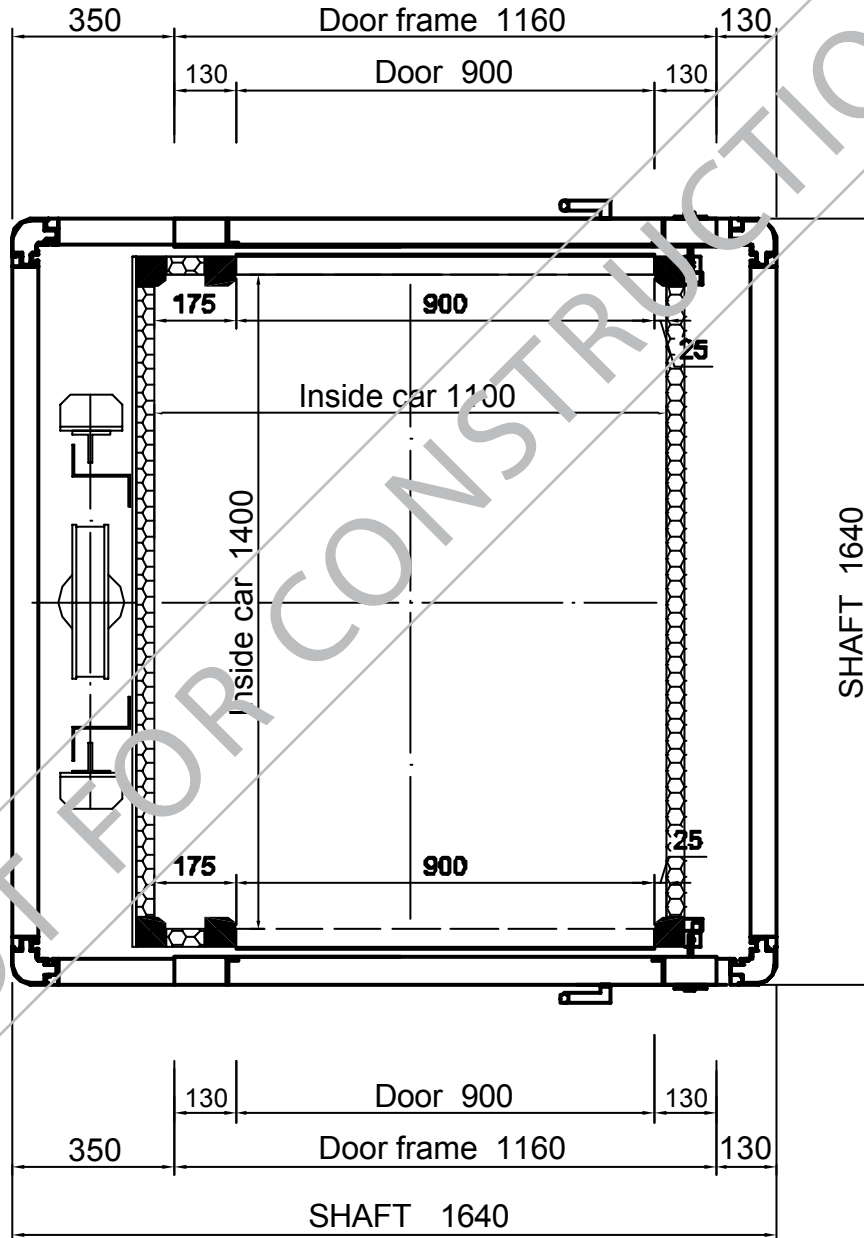

MACHINERY CABINET  
 720Wx360Dx1500H

Copyright © Easy Living Home Elevators, July 2005

SPECIFICATIONS					
Application	Carrying Capacity	Pit Depth (mm)	Headroom (mm)	Max Travel (mm)	Speed (m/sec)
Residential AS1735.18	400kg	130	2500	12,000	0.25
Commercial AS1735.15	400kg	130	2500	4,000	0.15



For reference only: NOT FOR CONSTRUCTION.  
 Please contact our sales representative for more information.

NSW  
 T. 02 9907 4634

VIC  
 T. 03 9427 0122

QLD  
 T. 07 3216 2670